

Sun Sensor for small satellites with digital interface

Sun Sensor on a Chip (SSOC), is based on MEMS fabrication processes to achieve highly integrated sensing structures for high accurate sun-tracking, positioning systems and attitude determination.

SSOC-D60 device measures the incident angle of a sun ray in both axis. It includes a microprocessor that directly provides the sun light incident angles and their derivatives without external calculations, via digital interface.

The high sensitivity is based on geometrical dimensions of the design. The use of a metal shield and a cover glass minimizes the ageing of the device under high radiation levels. Every sensor is calibrated and characterized.

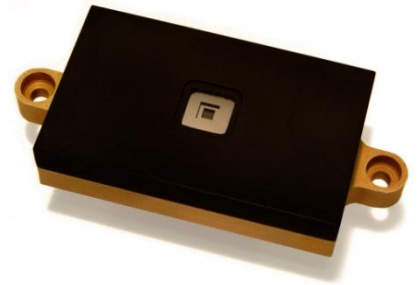

ITAR FREE

Technical specifications:

Parameter	SSOC-A60	Unit	Comments
Sensor type	2 axes	-	Orthogonal
Field of view (FOV)	$\pm 60^\circ$	$^\circ$	Angular size of the view cone
Accuracy	< 0.3	$^\circ$	3σ
Precision	< 0.05	$^\circ$	-
Average consumption	70	mA	-
Supply voltage	5	V	-
Interface	-	-	SPI, UART, I2C and RS422
Mass	35	g	-
Housing	6082		Aluminum, black anodizing

Qualification Data and Flight Heritage:

Data	Value
Operating Temperature	-45° to 85° Celsius
Radiation	30 kRad (gamma) 6 MeV 3000 kRad (protons)
Random vibration	14,1g @ 20-2000 Hz
Shock	3000 g @ 1-100 ms

It includes MEMS technology of Solar MEMS with flight heritage. Electronic components are space-grade, and included microprocessor has been tested according to space environment, and has flight heritage.

More than **50 units** included in more than 10 missions.

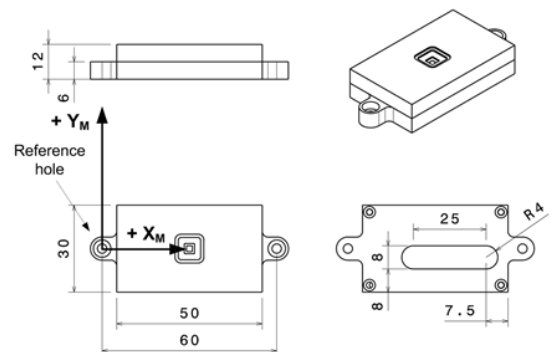

Mechanical layout and interface dimensions